



EXC-135SDR



Premium multiformat side belt case sealing machine

FEATURES

- Fully automatic case sealer
- Lateral drive belts
- Automatically adjusts to different carton sizes
- Top and bottom sealing
- Fitted with four swivel castors with brake

INSTREAM AND DOWNSTREAM CONVEYORS IN OPTION

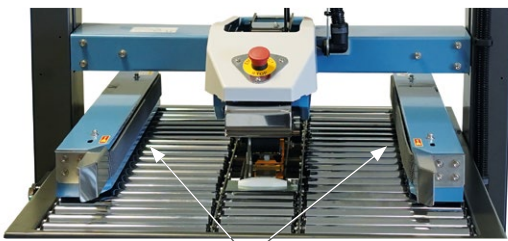

Side drive belts



Adjustable working height

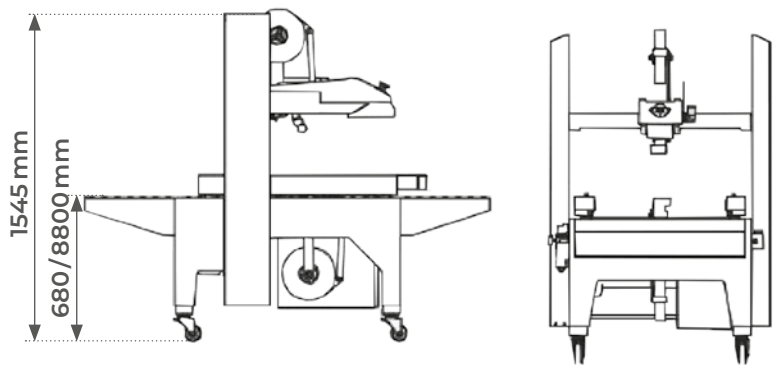
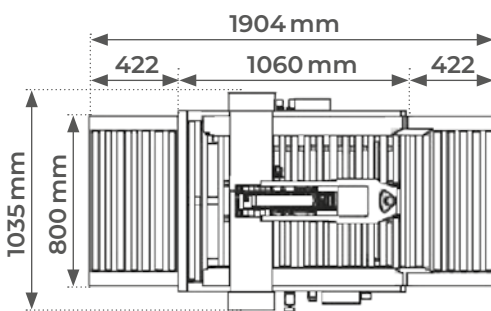

AVAILABLE IN OPTION

- Instream and downstream free roller conveyors
- Safety guarding



Model		EXC-135SDR
Adhesive tape width	mm	50 (75 en option)
Box dimensions (LxWxH)	mm	120 to ∞ / 110 to 600 / 100 to 600
Working height	mm	from 680 to 880
Speed	m/min	20
Power supply	V/Hz	220 single-phase / 50
Engine power	W	450
Dimensions (LxWxH)	mm	1060 (1904) x 1035 x 1545
Weight	kg	230