

EXC-133SD



Premium side belt case sealing machine

FEATURES

- Premium semi-automatic case sealer
- Lateral drive belts
- Adjustment by pneumatic cylinders
- Top and bottom sealing
- Case size simple set up
- Instream and downstream free roller conveyors
- Fitted with four swivel castors with brake

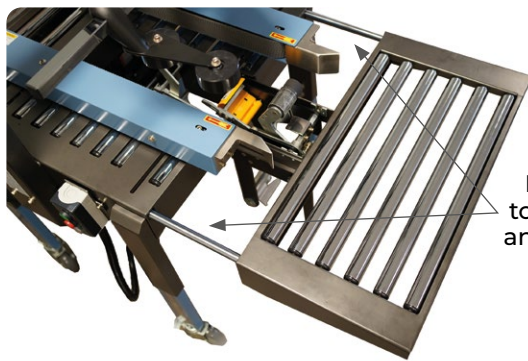

Extendable conveyor to install cutting blades and adhesive tape easily

Adjustable working height

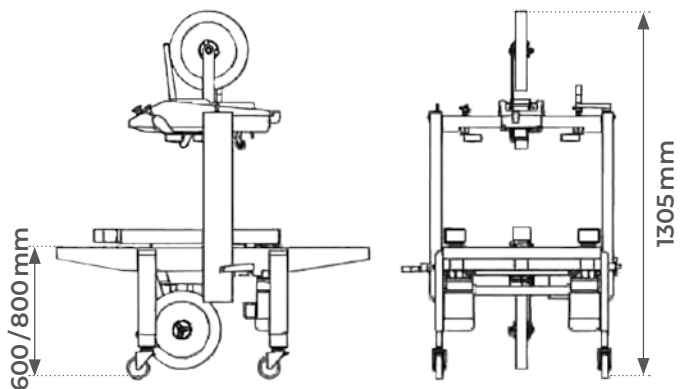
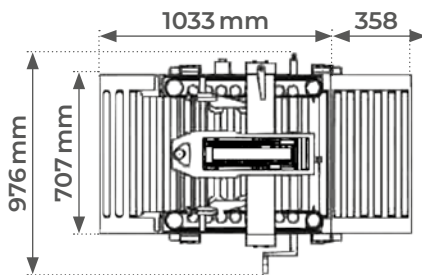

Model		EXC-133SD/2	EXC-133SD/3
Adhesive tape width	mm	50	75
Box dimensions (LxWxH)	mm	120 to ∞ / 110 to 500 / 120 to 500	120 to ∞ / 110 to 500 / 120 to 500
Working height	mm	from 600 to 800	from 600 to 800
Speed	m/min	23	23
Power supply	V/Hz	220 single-phase / 50	220 single-phase / 50
Engine power	W	450	450
Dimensions (LxWxH)	mm	1391 x 976 x 1305	1391 x 976 x 1305
Weight	kg	151	153