

# Heavy duty aluminum electric stair climber with crawlers

310 kg



## CT310

- Load capacity 310 kg
- Safe and easy to use
- Equipped with a removable lithium battery
- Automatic tilt adjustment of the load
- Automatic load compensation
- High-strength, non-slip rubber tracks
- Only suitable for straight stairs
- Equipped with a braking system
- Equipped with all-in-one remote control
- Supplied with charger, battery and strap strap
- Weight: 104 kg including 3 kg battery



All in one wire controller

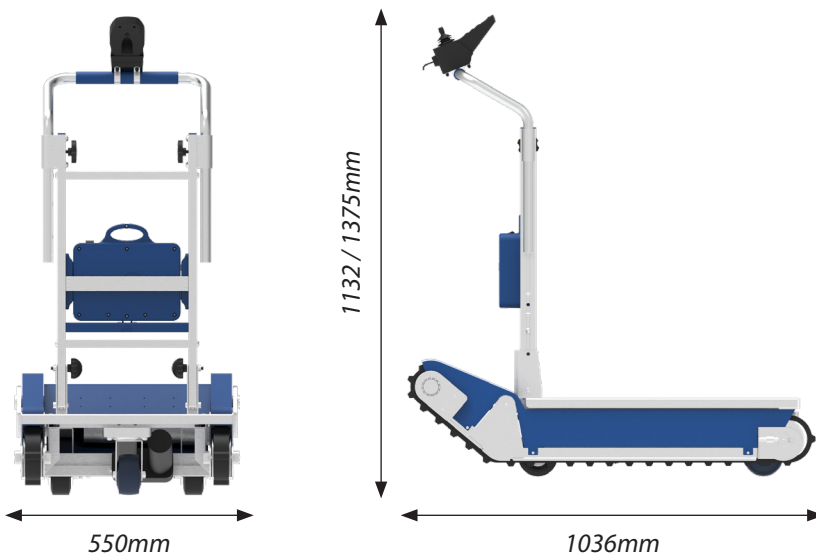

Model		CT310
Load capacity	kg	310
Overall dimensions (W x D x H)	mm	550x1036x1375
Dimensions folded (W x D x H)	mm	600x1036x1132
Climbing speed loaded	min	14-15 steps
Battery type		lithium
Battery voltage	V/Ah	24/17,5
Battery weight	kg	3,1
Charging time	h	4,5
Turning radius	mm	1500
Brakes		oui
Noise level	dB	< 70
IP code		IP 54
Step height (max) / angle	mm	210 / ≤ 50°
Weight	kg	72

